

## Control of Electric Boilers

Electric boilers contain several 5 KW elements that are usually staged to turn on and off with timed sequencers. You must break each element individually with a separate relay with line voltage control in order to control the elements.

To break the elements separately, you must have the control unit close enough to the boiler to make wiring with the line voltage economical, or you must use an Energy Sentry® Remote Relay Unit (see Tech Tip #10 for information).

Figure 1

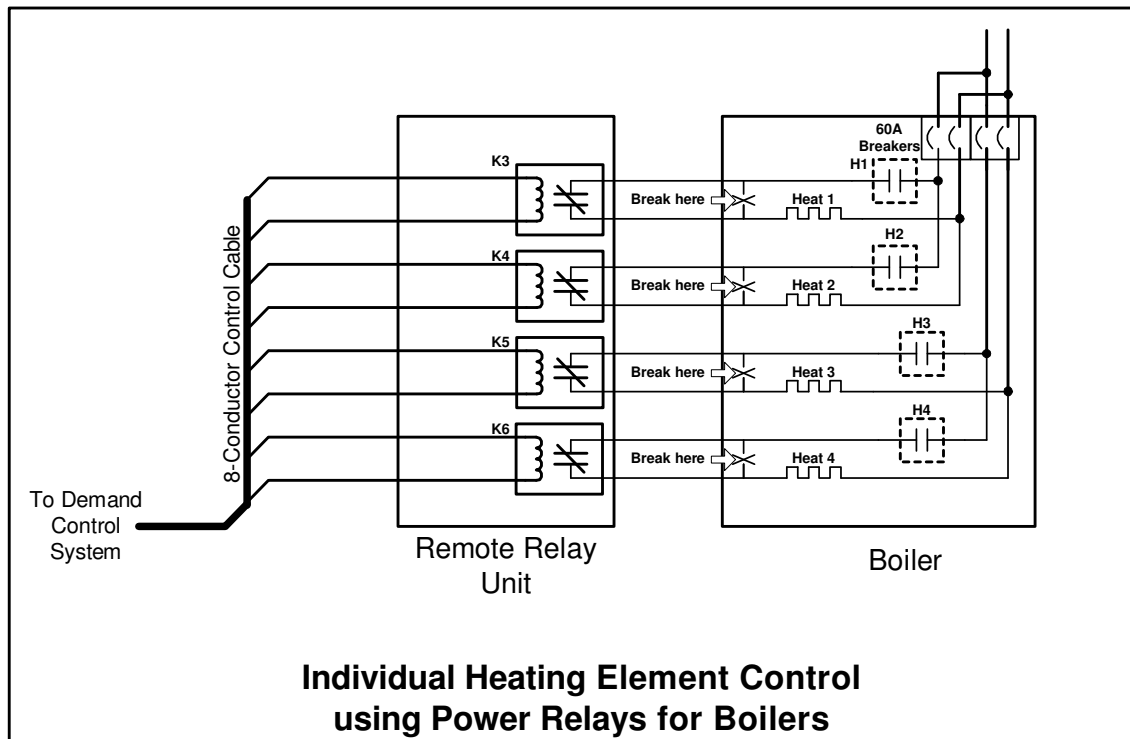

### Hook-up

1. Turn breaker(s) to the boiler OFF.
2. Mount Remote Relay Unit (if used) near the boiler to be controlled. Or, if the boiler is close enough to run conduit or flex between the main control unit and the boiler, make the connections directly at the control unit itself.
3. Interrupt the wires that feed each 5 KW element and wire them through the relays. Use one element per relay if possible (four elements are typical). Use two elements per relay if necessary (five or six elements are typical).
4. Hook up the Remote Relay Unit to the control unit using the instructions provided.
5. Depending on how the boiler controls turn on and turn off the elements, will determine how you set the load control strategy of the demand controller. If the sequencer rotates the elements in a "ring" so that the first element off is the first one on, then you should program the elements in a rotating strategy where each element has the same priority as the other elements. If, on the other hand, the sequencer controls the elements in a first on, last off priority sequence, then you will need to program the elements in a "fixed priority," in the same order as the they are controlled by the sequencer. Refer to Tech Tip #15 for information about load control strategy.

